

alberta[®]
The first name in Italian sofas

modern collection

HAMILTON
SIMON



4 hamilton



10 simon

index

hamilton



OHAMC12
tessuto | fabric | tissu | Stoff: 6641 Denim blue, cat. 6 - 529A Ibisco bianco, cat. 5 - 7051 Aran blue, cat. 7



Hamilton è un sistema modulare caratterizzato da una scocca importante rifinita da un grosso cordone (in contrasto o in tinta) che ne delimita il profilo. Si distingue dal modello Simon per l'abbinamento del cuscino di seduta e schienali. Hamilton ha un cuscino di seduta unico ed è arricchito da numerosi ed accoglienti cuscini sparsi (possono essere di colori diversi) che lo rendono giovane e disinvolto.

Hamilton is a modular system featuring a significant body characterised by a thick piping (with either contrasting or matching colour) running along the edge. The combination of seat and backrest cushions is what makes it different from the Simon model. Hamilton features a single cushion for the seat and is characterised by several scattered cushions (which can be offered in many different colours) giving it a young and relaxed look.

0HAMC1, 1HAPFFQ - tessuto | fabric | tissu | Stoff:
529A Ibisco bianco, cat. 5
525T Sand nero, cat. 5
529H Ibisco limetta, cat. 5
6116 Scacco nero piccolo, cat. 6



0HAMC1, 1HAPFFQ

Le **Hamilton** est un système modulaire caractérisé par une structure importante finie par un gros passepoil (contrasté ou ton sur ton) qui accentue les contours. Il se différencie du modèle Simon par la combinaison du coussin d'assise et de dossier. Le Hamilton a une assise avec coussin unique et il est enrichi par une multitude de petits coussins confortables (possibles dans de différentes couleurs) qui le rajeunissent et en font un canapé agréable.

Hamilton ist eine kombinierbare Polstergarnitur mit einem großen Korpus, dessen Konturen von einer dicken Kordel (in Kontrast- oder Ton-in-Ton-Ausführung) abgegrenzt wird. Es unterscheidet sich vom Modell Simon durch die Kombination des Sitzflächenkissens und der Rückenlehnenkissen. Hamilton besitzt ein durchgehendes Sitzflächenkissen und wird von zahlreichen kleineren, gemütlichen, verteilt positionierten Kissen bereichert (auch in verschiedenen Farben erhältlich), die ihm einen jungen, ungezwungenen Look geben.



OHAMC11

OHAMC11- tessuto | fabric | tissu | Stoff:
 407U Dora grigio medio, cat. 4
 529K Ibisco senape, cat. 5
 529H Ibisco limetta, cat. 5
 526Z Devon grigioperla, cat. 5



RAL 1003 Giallo segnale F 14



RAL 7042 Grigio traffico a



simon



1SIND3
tessuto | fabric | tissu | Stoff: 8133 Velour ottanio - 8140 Velour cielo, cat. 8

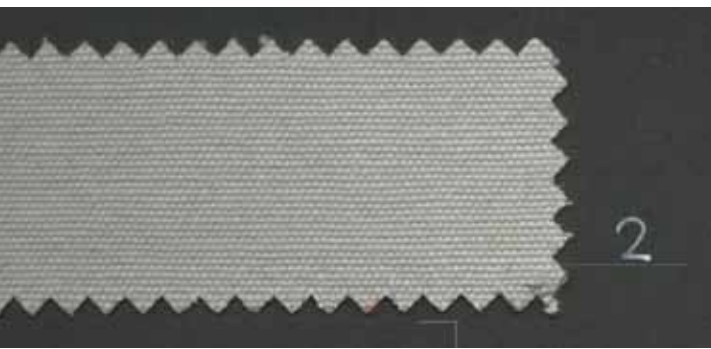

Sistema modulare caratterizzato da una scocca importante rifinita da un grosso cordone (in contrasto o in tinta) che ne delimita il profilo. Si distingue dal modello Hamilton per l'abbinamento dei cuscini di seduta e schienale. Simon è definito da cuscini di seduta e schienale ben distinti che gli donano un carattere borghese. Opzionale la seduta con cuscino unico.

A modular system featuring a significant body characterised by a thick piping (with either contrasting or matching colour) running along the edge. The combination of seat and backrest cushions is what makes it different from the Hamilton model. Simon stands out for its clearly defined seat and backrest cushions, which give it an elegant look. Single cushion for the seat provided as optional.

OSINC1 - tessuto | fabric | tissu | Stoff:
529T Ibisco antracite, cat. 5
529B Ibisco cenere, cat. 5





Système modulaire caractérisé par une structure importante finie par un gros passepoil (contrasté ou ton sur ton) qui accentue les contours. Il se différencie du modèle Hamilton par la combinaison des coussins d'assise et de dossier. Simon est défini par des coussins d'assise et de dossier bien distincts qui lui donnent un caractère bourgeois.
En option, l'assise avec coussin unique.

Kombinierbare Polstergarnitur mit einem großen Korpus, dessen Konturen von einer dicken Kordel (in Kontrast- oder Ton-in-Ton-Ausführung) abgegrenzt wird. Es unterscheidet sich vom Modell Hamilton durch die Kombination der Sitzflächen- und Rückenlehnenkissen. Simon zeichnet sich durch klar unterschiedene Sitzflächen- und Rückenlehnenkissen aus, die ihm ein eher bürgerliches Aussehen verleihen. Optional Sitzfläche mit durchgehendem Kissen.

OSINC7 - tessuto | fabric | tissu | Stoff:
525A laguna bianco, cat. 5



OSINC7

HAMILTON
Tessuto / fabric / tissu / Stoff

Composizioni / composition / compositions / Kompositionen

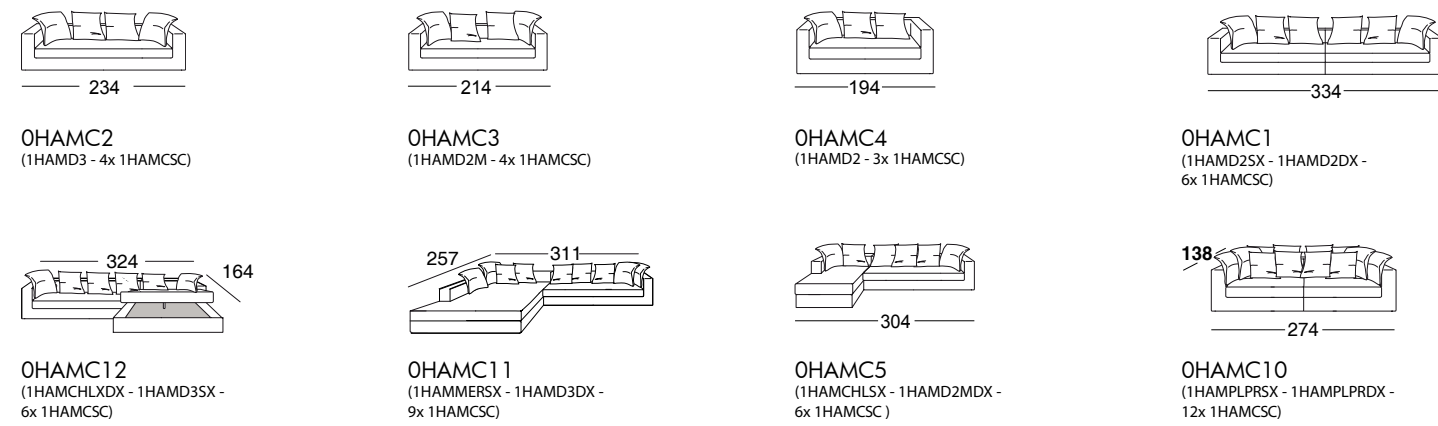

Elementi / elements / elements / Elemente

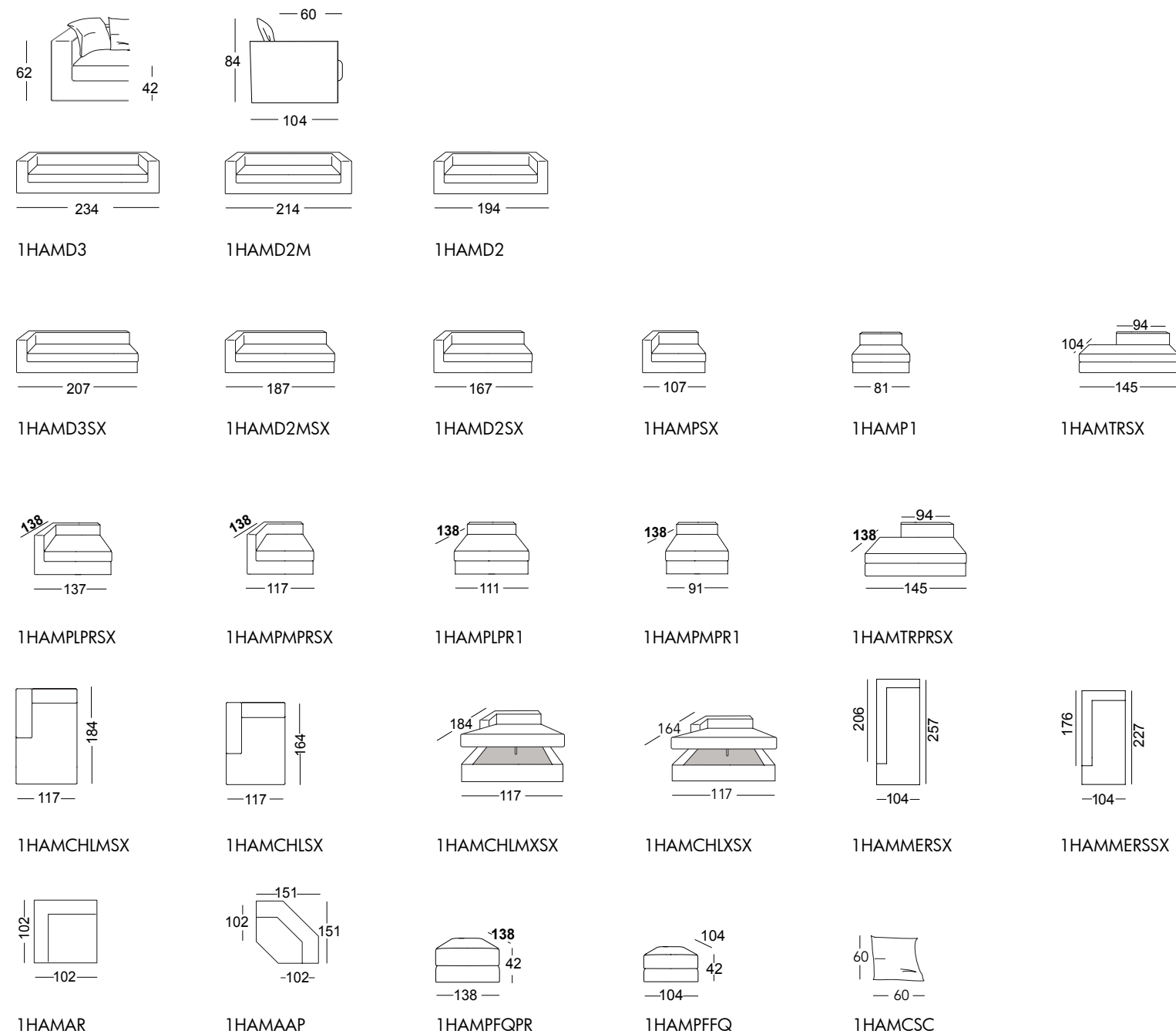

Elementi / elements / elements / Elemente

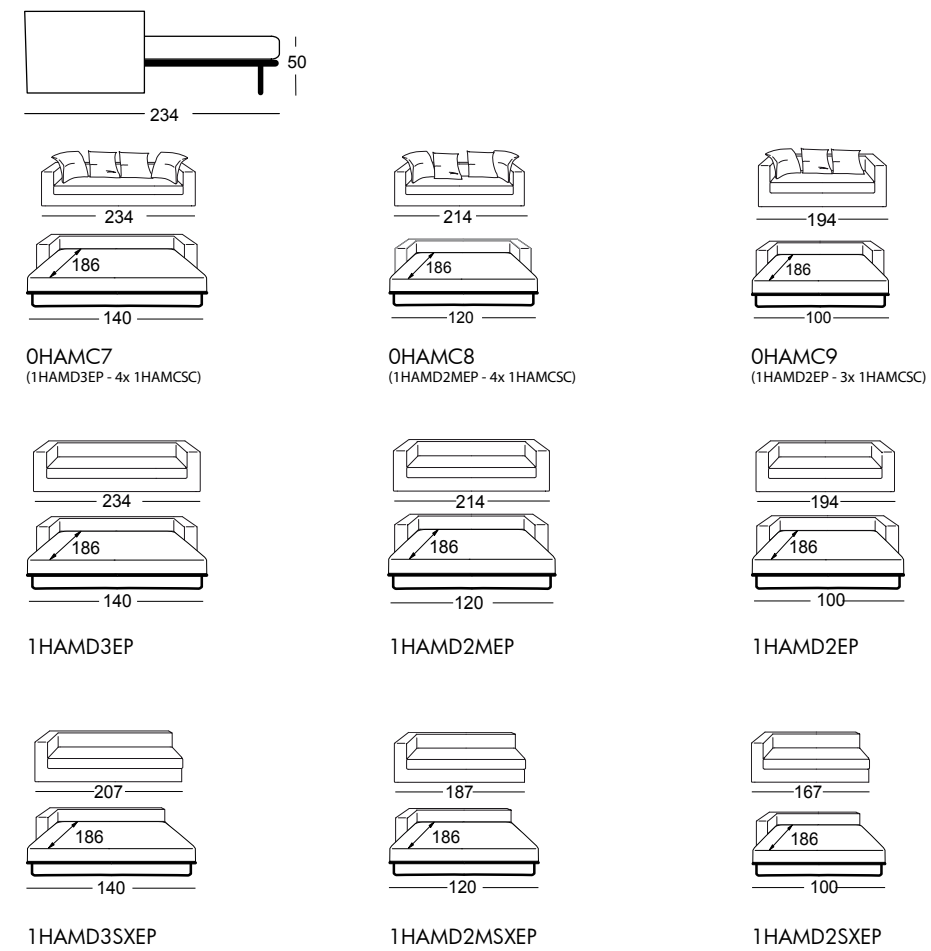

Struttura portante in massello di legno. Cuscino di seduta in piuma d'oca e fibra di poliestere con inserto in poliuretano espanso. Cuscino di schienale in piuma d'oca e fibra di poliestere rivestito in fodera di cotone.

Main structure in solid wood. Seat cushions in goose feathers and polyester fibre with internal padding in polyurethane foam. Backrest cushions in goose feathers and polyester fibre covered with cotton lining.

Carcasse principal en bois massif. Assise en polyuréthane expansé avec partie supérieur en plumes d'oie et fibre de polyester. Dossier en plumes d'oie et fibre de polyester sous housse de coton.

Tragstruktur aus massivholz (Schichtholz). Sitzkissen aus Polyurethanschaum Oberteil aus Gänsedaunen und Polyesterfaser. Rückenkissen aus Gänsedaunen und Polyesterfaser Abgedeckt mit Baumwolle.

SIMON

Tessuto / fabric / tissu / Stoff

Composizioni / composition / compositions / Kompositionen

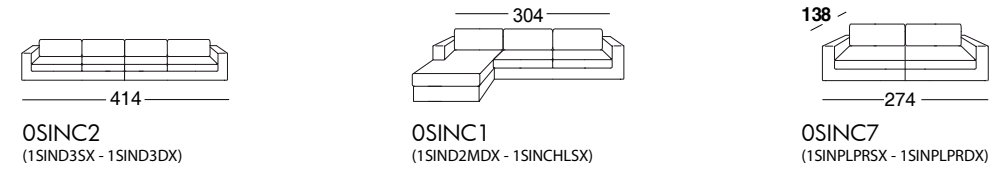

Elementi / elements / elements / Elemente

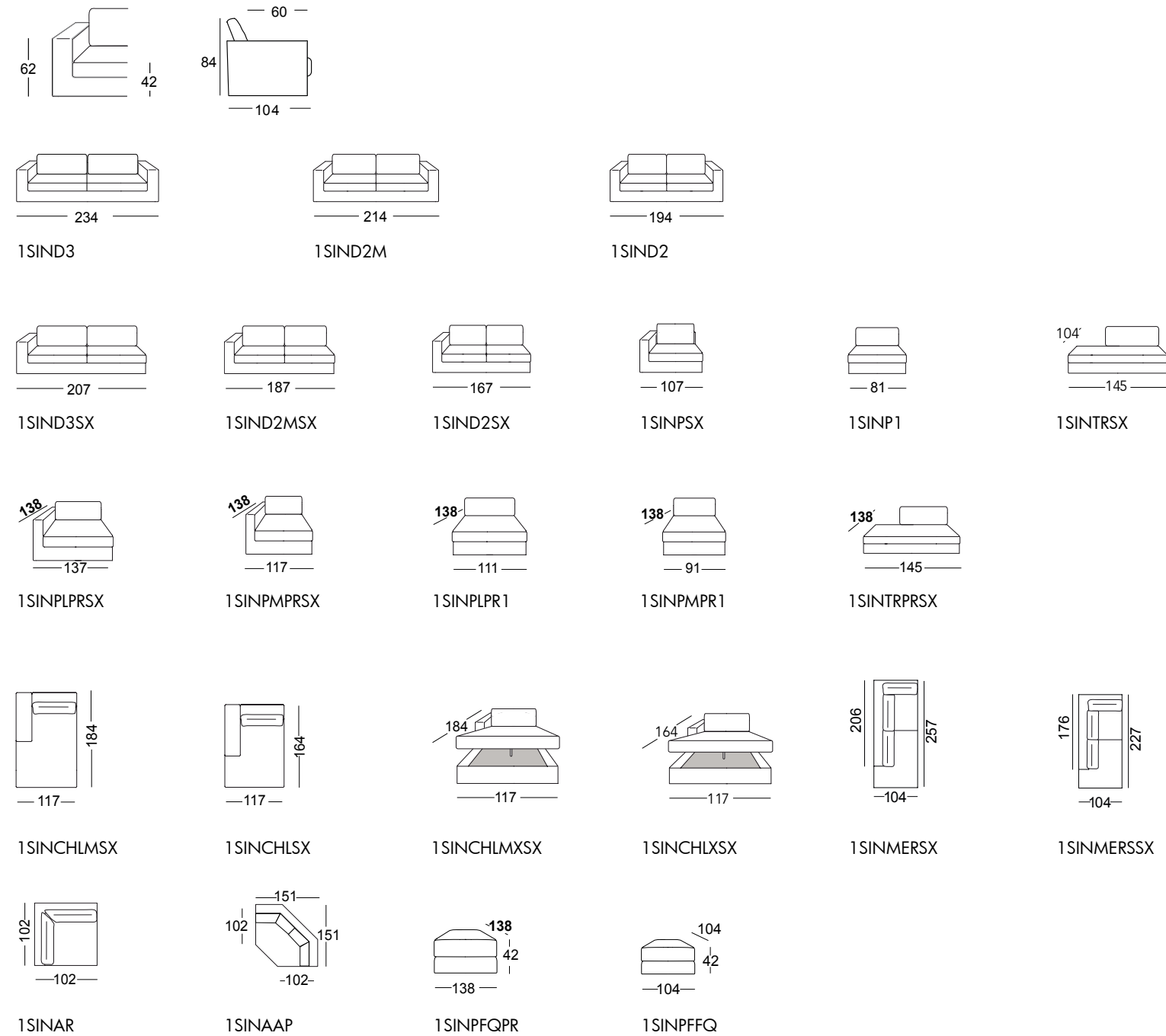

Elementi / elements / elements / Elemente

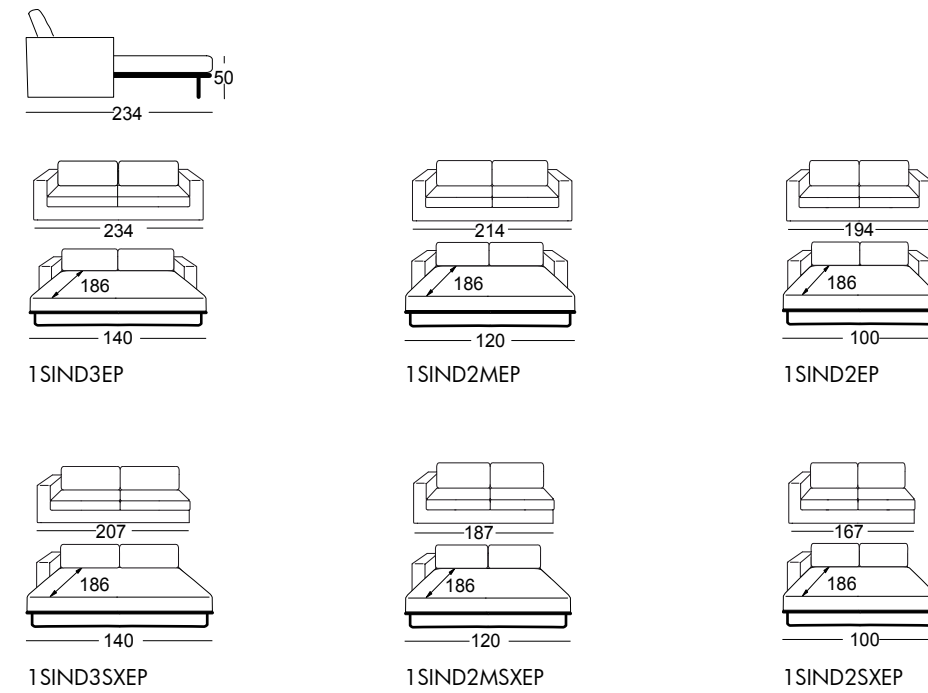

Struttura portante in massello di legno. Cuscino di seduta in piuma d'oca e fibra di poliestere con inserto in poliuretano espanso. Cuscino di schienale in piuma d'oca e fibra di poliestere rivestito in fodera di cotone.

Main structure in solid wood. Seat cushions in goose feathers and polyester fibre with internal padding in polyurethane foam. Backrest cushions in goose feathers and polyester fibre covered with cotton lining.

Carcasse principal en bois massif. Assise en polyuréthane expansé avec partie supérieur en plumes d'oie et fibre de polyester. Dossier en plumes d'oie et fibre de polyester sous housse de coton.

Tragstruktur aus massivholz (Schichtholz). Sitzkissen aus Polyurethanschaum Oberteil aus Gänsedaunen und Polyesterfaser. Rückenkissen aus Gänsedaunen und Polyesterfaser Abgedeckt mit Baumwolle.

